

mounting direction

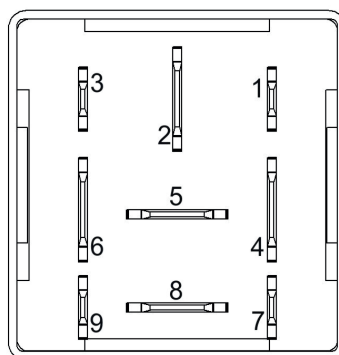

view of plug

DESCRIPTION

The compact Micro Gateway CAN Serial complements existing systems and mediates or manipulates information between local interfaces (CAN, RS232/485). It provides a 1-Wire interface that can be used to connect an iButton reader for authentication or tracking.

TECHNICAL DATA

Housing	Plastic PA 66GF30
Connector	Base plate 9-pin
Weight	32 g
Temperature range (ISO 16750-4 compliant)	-40 °C to +85 °C
Environmental protection	IP 6K8 with correct installation position and use of the waterproof socket
Current consumption	8 mA at 12 V and 24 V
Over-current protection	see max. switching current
Total Inputs and outputs	1 input / 2 outputs (3)
Inputs	Configurable as: Analog/digital input 0...16.9/30 V
Outputs	Configurable as: Digital, positive switching (high side) PWM output (3 Hz...1000 Hz)
Operating voltage	9-32 V (cf. p. 6) acc. to ISO 16750-2: 12 V (Code A) 24 V (Code E)
Overvoltage protection	from approx. 36 V
Quiescent current	30 µA at 12 V 750 µA at 24 V
Reverse polarity protection	Yes
CAN interfaces	CAN interface 2.0 A/B, ISO 11898-2

REGULATORY APPROVALS AND TESTING

E1 approval	On request
Electrical tests	Acc. to ISO 16750 – 2 resp. -4: Short circuit protection (without OneWire Interface) Reverse polarity Interruption pin and connector Overvoltage at TMax-20 °C Storage test at TMax and TMin Operation test at TMax and TMin Starting profile (form. pulse 4 according to ISO 7637) Acc. to ISO 7637 - 2: Pulse 1, 2a, 2b, 3a, 3b, severity III

SOFTWARE/PROGRAMMING

Programming System

MRS Developers Studio

MRS Developers Studio with built-in functions library, similar programming with FUP. Custom software blocks can be integrated into "C-code". Program memory is sufficient for about 300 basic logic components.

INPUT FEATURES - SUMMARY

Pin 4 (KL15) Programmable as analog or digital input Resolution 12 Bit Accuracy 1% full scale	Voltage input 0...16.9 V (see A)	Input resistance 51 kΩ Input frequency $f_g^1 = 130$ Hz Accuracy ≤ 3 %	Pin 1 (One Wire Interface) One Wire Interface input (see C) Input high min. 3.4 V Input low max. 1.8 V Voltage level RX/TX 5 V
	Voltage input 0...30 V (see B)	Input resistance 41 kΩ Input frequency $f_g^1 = 250$ Hz Conversion factor ≈ 1.95 Digit/mV	

¹ cutoff frequency (-3 dB)

OUTPUT FEATURES - SUMMARY

Pin 3, 5 (HSD output) Protective circuit for inductive loads Wire fault diagnostics Short circuit diagnostics	Not integrated	Pin 8 (Relay NO, optional) Protective circuit for inductive loads Wire fault diagnostics Short circuit diagnostics	Not integrated
	Possible via current sense		Not available
Digital, positive switching (high side; see D)	Switching voltage 9-32 V max. switching current each channel ² 4.7 A when using both channels	Digital, positive switching (see E)	9-32 V see datasheet Song Chuan 103-1CH-S 12V Pin 4
PWM output (see D)	Output frequency 0...1000 Hz max. switching current ³ 2 A at 1000 Hz 2.9 A at 500 Hz 3.7 A at 200 Hz	COM connection	external fuse protection required
Short circuit resistance against GND and US	Conversion factor see diagram Current sense ⁴ Switching-off is controlled by high side driver for each output channel	Short circuit resistance against GND	

² measured at $U_B = 28$ V, +85 °C

³ measured at $U_B = 28$ V, 90 % DC, +85 °C

⁴ current sense 0...1 A

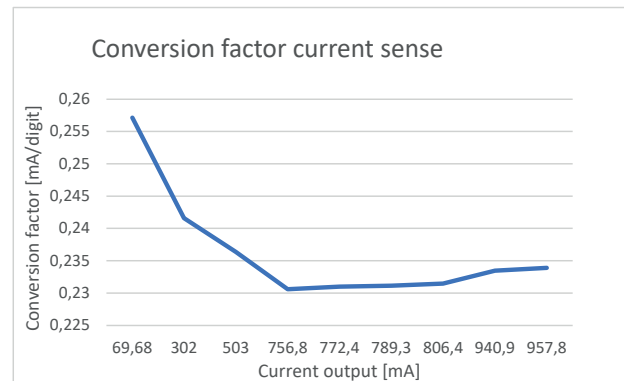

PIN ASSIGNMENT POWER SUPPLY AND INTERFACES

Pin	Description	Pin	Description
1	One Wire interface	7	CAN - H
2	Operating voltage terminal 30	8	optional RS232TX / RS485B
4	Terminal 15 / ignition/ (optional RS232RX / RS485A)	9	CAN - L
6	Ground		

PIN ASSIGNMENT INPUTS AND OUTPUTS

Pin	Signal	Description	Pin	Signal	Description
2	AI_VDD	Analog input für KL30 Messung	4	AI_KL15 DO_RS1	Analog input KL15 0...16.9 V with Bereichsumschaltung 0...30 V
3	DO_PWM_HSD_ OUT1 PWM_HSD_OUT1 AI_SNS_HSD1	Digital output HSD1 with PWM option and current sense to max. 1 A	5	DO_PWM_HSD_ OUT2 PWM_HSD_OUT2 AI_SNS_HSD2	Digital output HSD1 with PWM option and current sense
			8	DO_REL	Digital output Relay

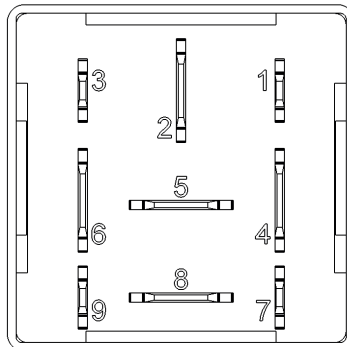

PIN FEATURE MAP

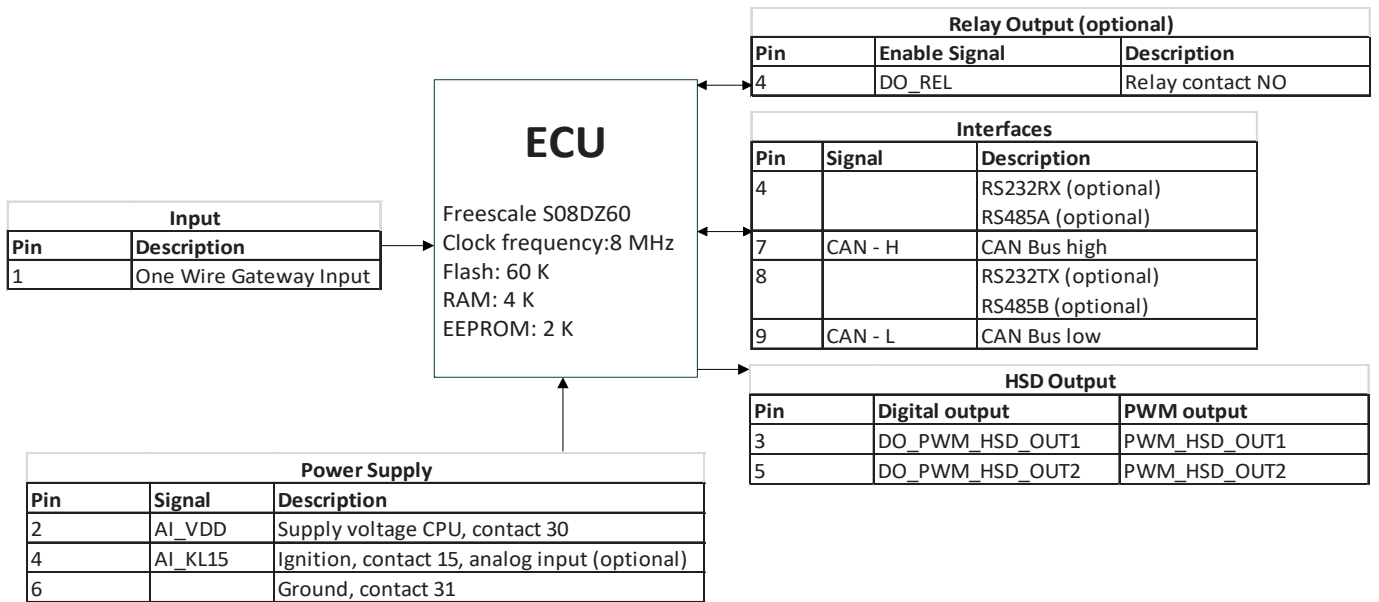

BLOCK FUNCTION DIAGRAM

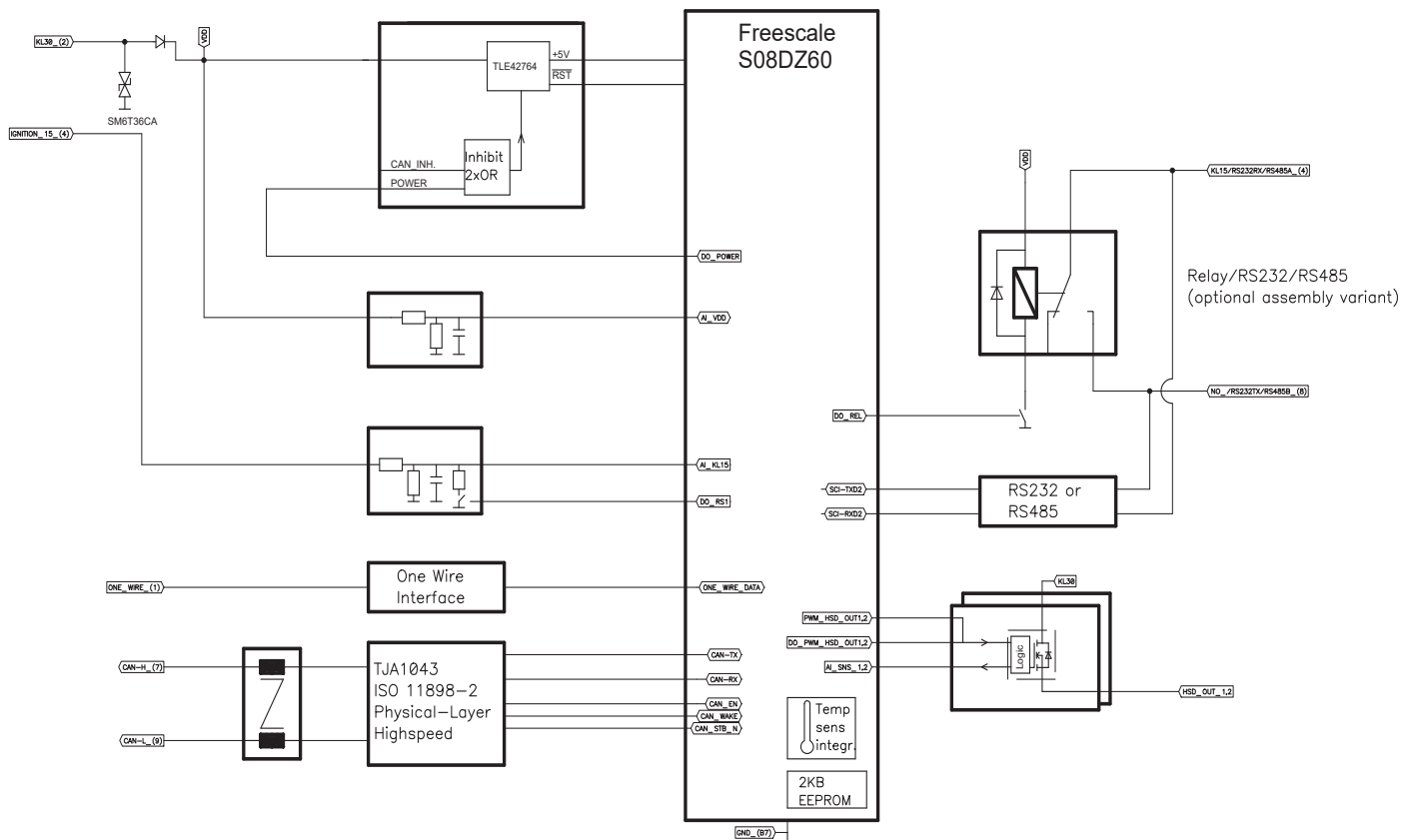

TECHNICAL DRAWING IN MM [INCH]

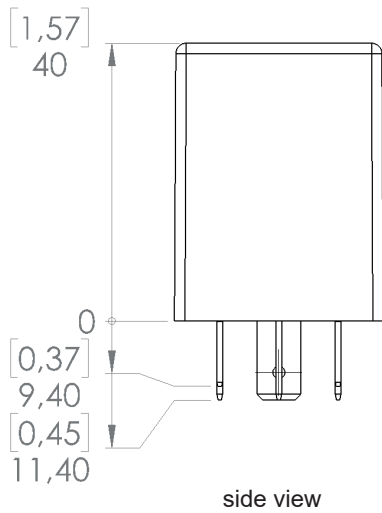

side view

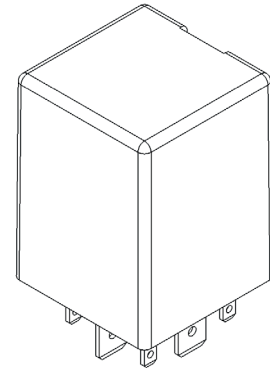

angled view

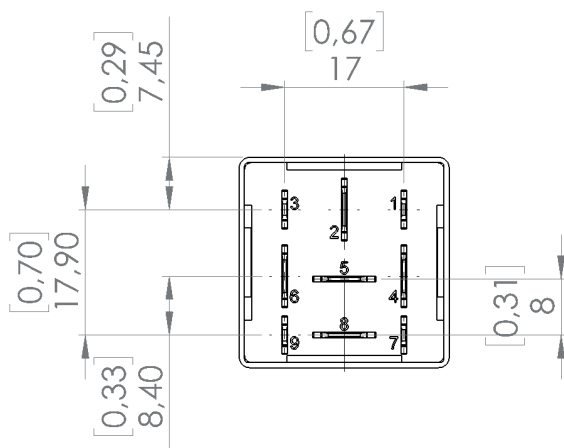

bottom view

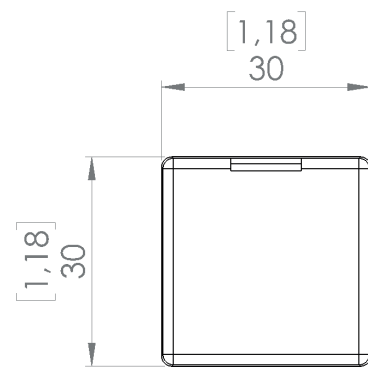

top view

ASSEMBLY OPTIONS AND ORDER INFORMATION

	Inputs			Outputs		CAN bus	Serial interface		Wake-up source	Remarks
	A Voltage 0...16.9 V	B Voltage 0...30 V	C One Wire input	D HSD output	E Relay		RS232	RS485		
1.174.300.0000	4	4	1	3, 5	8	7, 9			CAN, DO_POWER	
1.174.310.0000			1	3, 5		7, 9	4, 8		CAN, DO_POWER	
1.174.320.0000			1	3, 5		7, 9		4, 8	CAN, DO_POWER	
1.174.330.0000			1				4, 8		-	direct conversion RS232 to OneWire interface, without CPU

ACCESSORIES

Description	Order number
Programming tool MRS Developers Studio	1.100.100.09
Socket package watertight 40 mm	114265
Connector	1.017.002.00
FASTON terminal latch 2,8 mm 0,5 – 1,0 mm ²	105292
FASTON terminal latch 6,3 mm 1,0 mm ²	102355
PCAN-USB interface 105358	105358



MANUFACTURER

MRS Electronic GmbH & Co. KG
Klaus-Gutsch-Str. 7
78628 Rottweil
Germany

NOTES ON WIRING AND CABLE ROUTING

PWM outputs may not be connected with each other or bypassed.

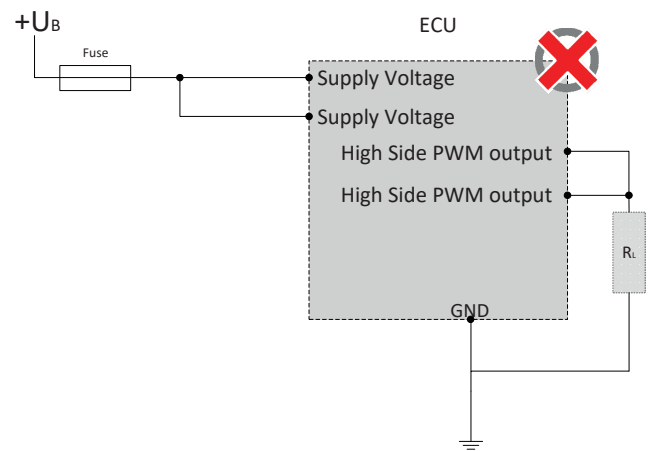
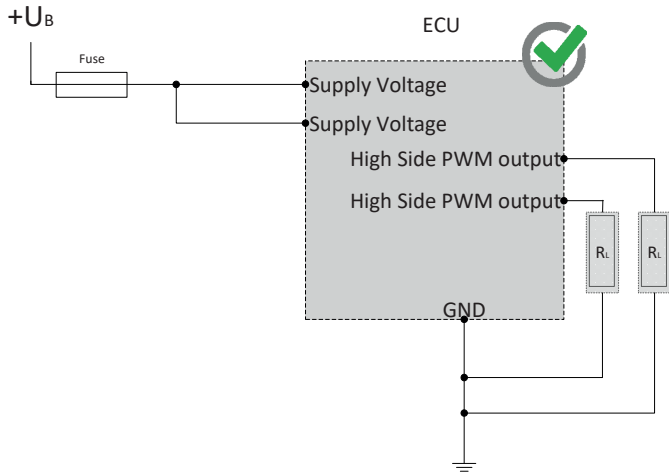

The pins (I/Os) can be used in combination and may not be switched externally against a higher voltage level than supply voltage.

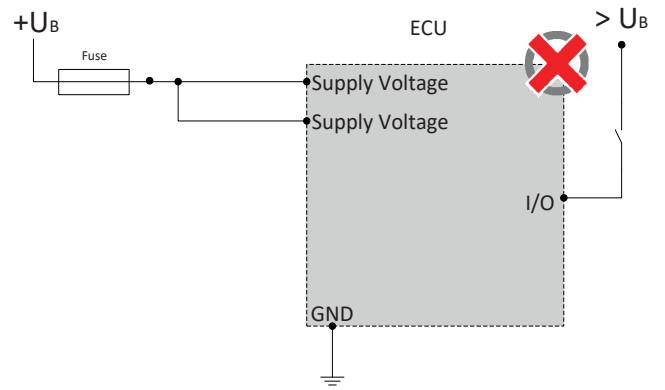
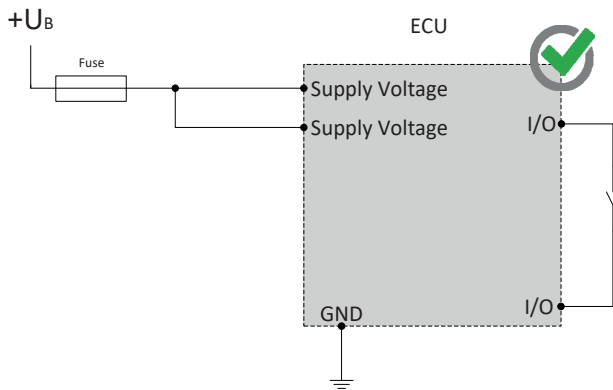

Hightside outputs may only be switched to ground.

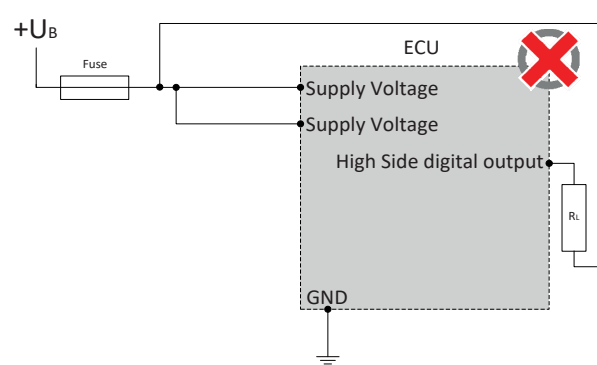
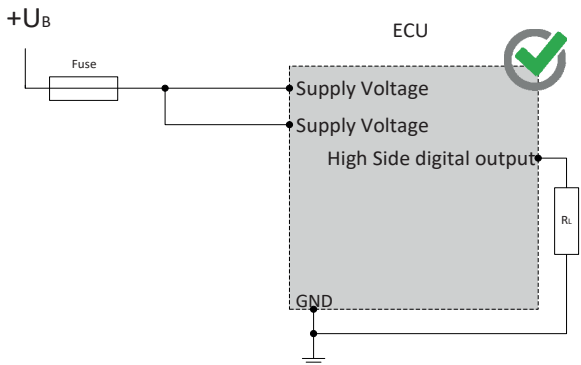

NOTES ON WIRING AND CABLE ROUTING

CAN bus communication is the main communication between the control unit and the vehicle. Therefore, connect the CAN bus with special care and check the correct communication with the vehicle to avoid undesired behavior.

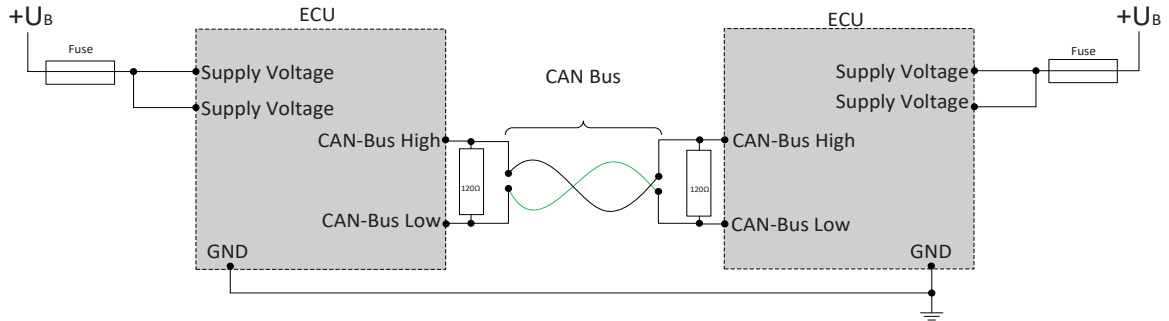

SAFETY AND INSTALLATION INFORMATION

It is essential to read the instructions in full thoroughly before working with the device.

Please note and comply with the instructions in the operating instructions and the information in the device data sheet, see www.mrs-electronic.com

Staff qualification: Only staff with the appropriate qualifications may work on this device or in its proximity.

SAFETY



WARNING! Danger as a result of a malfunction of the entire system.

Unforeseen reactions or malfunctions of the entire system may jeopardise the safety of people or the machine.

- Ensure that the device is equipped with the correct software and that the wiring and settings on the hardware are appropriate.



WARNING! Danger as a result of unprotected moving components.

Unforeseen dangers may occur from the entire system when putting the device into operation and maintaining it.

- Switch the entire system off before carrying out any work and prevent it from unintentionally switching back on.
- Before putting the device into operation, ensure that the entire system and parts of the system are safe.
- The device should never be connected or separated under load or voltage.



CAUTION! Risk of burns from the housing.

The temperature of the device housing may be elevated.

- Do not touch the housing and let all system components cool before working on the system.

PROPER USE

The device is used to control or switch one or more electrical systems or sub-systems in motor vehicles and machines and may only be used for this purpose. The device may only be used in an industrial setting.



WARNING! Danger caused by incorrect use.

The device is only intended for use in motor vehicles and machines.

- Use in safety-related system parts for personal protection is not permitted.
- Do not use the device in areas where there is a risk of explosion.

Correct use:

- operating the device within the operating areas specified and approved in the associated data sheet.
- strict compliance with these instructions and no other actions which may jeopardise the safety of individuals or the functionality of the device.

Obligations of the manufacturer of entire systems

It is necessary to ensure that only functional devices are used. If devices fail or malfunction, they must be replaced immediately.

System developments, installation and the putting into operation of electrical systems may only be carried out by trained and experienced staff who are sufficiently familiar with the handling of the components used and the entire system.

It is necessary to ensure that the wiring and programming of the device does not lead to safety-related malfunctions of the entire system in the event of a failure or a malfunction. System behaviour of this type can lead to a danger to life or high levels of material damage.

The manufacturer of the entire system is responsible for the correct connection of the entire periphery (e.g. cable cross sections, correct selection/connection of sensors/actuators).

Opening the device, making changes to the device and carrying out repairs are all prohibited. Changes or repairs made to the cabling can lead to dangerous malfunctions. Repairs may only be carried out by MRS.

Installation

The installation location must be selected so the device is exposed to as low a mechanical and thermal load as possible. The device may not be exposed to any chemical loads.

Install the device in such a manner that the plugs point downwards. This means condensation can flow off the device. Single seals on the cables/leads must be used to ensure that no water gets into the device.

Putting into operation

The device may only be put into operation by qualified staff. This may only occur when the status of the entire system corresponds to the applicable guidelines and regulations.

FAULT CORRECTION AND MAINTENANCE



NOTE The device is maintenance-free and may not be opened.

- If the device has damage to the housing, latches, seals or flat plugs, it must be taken out of operation.

Fault correction and cleaning work may only be carried out with the power turned off. Remove the device to correct faults and to clean it.

Check the integrity of the housing and all flat plugs, connections and pins for mechanical damage, damage caused by overheating, insulation damage and corrosion. In the event of faulty switching, check the software, switches and settings.

Do not clean the device with high pressure cleaners or steam jets. Do not use aggressive solvents or abrasive substances.