

Mounting view (depending on assembly)

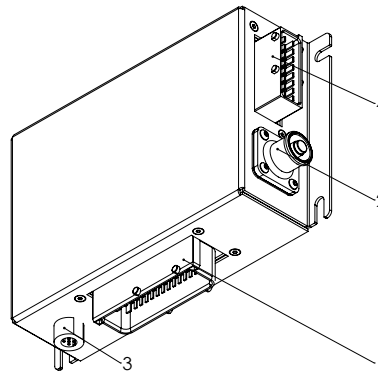

Plug view (depending on assembly)

DESCRIPTION

The CC27WP is a powerful and robust 32-bit controller with 27 inputs and outputs and 16 freely configurable I/Os with voltage and current diagnostics. It has 7 multi-function inputs and 4 half bridges for controlling motors. Due to the free configurability and high flexibility you can use the CC27WP independent of the industry.

TECHNICAL DATA

Connector	4: TE 1-963215-1 JPT 16 pol
Total inputs and outputs of the Power-Extension	16 I/Os,
Inputs	Analog inputs I/Os 0...32 V
Outputs	Digital, positive switching
Fuse protection	120 A

ADDITIONAL INPUTS FEATURES - SUMMARY (CONNECTOR 4)

Pin 1, 2, 3, 4, 5, 6, 7, 8, 9, 10, 11, 12, 13, 14, 15, 16	Programmable as Analog- or Digital input	Resolution	12 Bit
Voltage input 0...32 V (across multiplexer, see A)	Input resistance	65 kΩ	
	Input frequency	$f_g^1 = 190 \text{ Hz}$	
	Deviation	from 2 V $\leq 3 \%$	
Digital input ³	Input resistance	65 kΩ	
	Switch-on threshold	6.1 V $\pm 0.3 \text{ V}$	
	Switch-off threshold	4.1 V $\pm 0.3 \text{ V}$	

¹Cut-off frequency (-3 dB), measured with square signal 0...10 V_{Peak}

ADDITIONAL HIGHSIDE-OUTPUTS FEATURES - SUMMARY (CONNECTOR 4)

Pin 1, 2, 3, 4, 5, 6, 7, 8, 9, 10, 11, 12, 13, 14, 15, 16 (BTS)	Protective circuit for inductive loads	Integrated
	Diagnosis of wire breakage	Via current sense
	Diagnosis short circuit	Via current sense
Digital, positive switching (High-Side; see A)	Switching voltage	9-32 V DC
	Switching current	see load tests
	Current sense	only for diagnosis purposes
Short circuit resistance against GND and V_s	Switching-off is controlled by high side driver for each output channel	
Protective circuit overload	Overtemperature shutdown integrated	

LOAD TESTS AT $T_{+85^{\circ}\text{C}}$ ADDITIONAL HSD-OUTPUTS

Test voltage	Load	Duration
@ 12 V U_B	1 = 12 A	Permanent
	2 = 4 A	
	3 = 4 A	
	4 = 4 A	
	5 = 4 A	
	6 = 4 A	
	7 = 4 A	
	8 = 6 A	
	9 = 6 A	
	10 = 6 A	
	11 = 6 A	
	12 = 6 A	
	13 = 6 A	
	14 = 6 A	
	15 = 6 A	
	16 = 6 A	
	($\Sigma=90$ A)	

The total current over the entire assembly (base and power extension) must not exceed 135 A at +85°C.

PIN ASSIGNMENT ADDITIONAL IN- AND OUTPUTS (CONNECTOR 4)

Pin	Programm Signal	Pin Description	Pin	Programm Signal	Pin Description
1	AIM_PIGGY_IO1 DOM_PIGGY_HSD_OUT1 AIM_PIGGY_HSD_SENSE1	Analog input Piggy 1 or Digital output Piggy 1 with Current sense	10	AIM_PIGGY_IO10 DOM_PIGGY_HSD_OUT10 AIM_PIGGY_HSD_SENSE10	Analog input Piggy 10 or Digital output Piggy 10 with Current sense
2	AIM_PIGGY_IO2 DOM_PIGGY_HSD_OUT2 AIM_PIGGY_HSD_SENSE2	Analog input Piggy 2 or Digital output Piggy 2 with Current sense	11	AIM_PIGGY_IO11 DOM_PIGGY_HSD_OUT11 AIM_PIGGY_HSD_SENSE11	Analog input Piggy 11 or Digital output Piggy 11 with Current sense
3	AIM_PIGGY_IO3 DOM_PIGGY_HSD_OUT3 AIM_PIGGY_HSD_SENSE3	Analog input Piggy 3 or Digital output Piggy 3 with Current sense	12	AIM_PIGGY_IO12 DOM_PIGGY_HSD_OUT12 AIM_PIGGY_HSD_SENSE12	Analog input Piggy 12 or Digital output Piggy 12 with Current sense
4	AIM_PIGGY_IO4 DOM_PIGGY_HSD_OUT4 AIM_PIGGY_HSD_SENSE4	Analog input Piggy 4 or Digital output Piggy 4 with Current sense	13	AIM_PIGGY_IO13 DOM_PIGGY_HSD_OUT13 AIM_PIGGY_HSD_SENSE13	Analog input Piggy 13 or Digital output Piggy 13 with Current sense
5	AIM_PIGGY_IO5 DOM_PIGGY_HSD_OUT5 AIM_PIGGY_HSD_SENSE5	Analog input Piggy 5 or Digital output Piggy 5 with Current sense	14	AIM_PIGGY_IO14 DOM_PIGGY_HSD_OUT14 AIM_PIGGY_HSD_SENSE14	Analog input Piggy 14 or Digital output Piggy 14 with Current sense
6	AIM_PIGGY_IO6 DOM_PIGGY_HSD_OUT6 AIM_PIGGY_HSD_SENSE6	Analog input Piggy 6 or Digital output Piggy 6 with Current sense	15	AIM_PIGGY_IO15 DOM_PIGGY_HSD_OUT15 AIM_PIGGY_HSD_SENSE15	Analog input Piggy 15 or Digital output Piggy 15 with Current sense
7	AIM_PIGGY_IO7 DOM_PIGGY_HSD_OUT7 AIM_PIGGY_HSD_SENSE7	Analog input Piggy 7 or Digital output Piggy 7 with Current sense	16	AIM_PIGGY_IO16 DOM_PIGGY_HSD_OUT16 AIM_PIGGY_HSD_SENSE16	Analog input Piggy 16 or Digital output Piggy 16 with Current sense
8	AIM_PIGGY_IO8 DOM_PIGGY_HSD_OUT8 AIM_PIGGY_HSD_SENSE8	Analog input Piggy 8 or Digital output Piggy 8 with Current sense			
9	AIM_PIGGY_IO9 DOM_PIGGY_HSD_OUT9 AIM_PIGGY_HSD_SENSE9	Analog input Piggy 9 or Digital output Piggy 9 with Current sense			

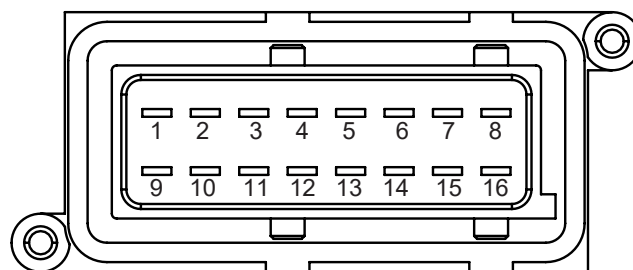

Pin assignment Connector 16 Pin (4)

TECHNICAL DRAWING IN MM [INCH]

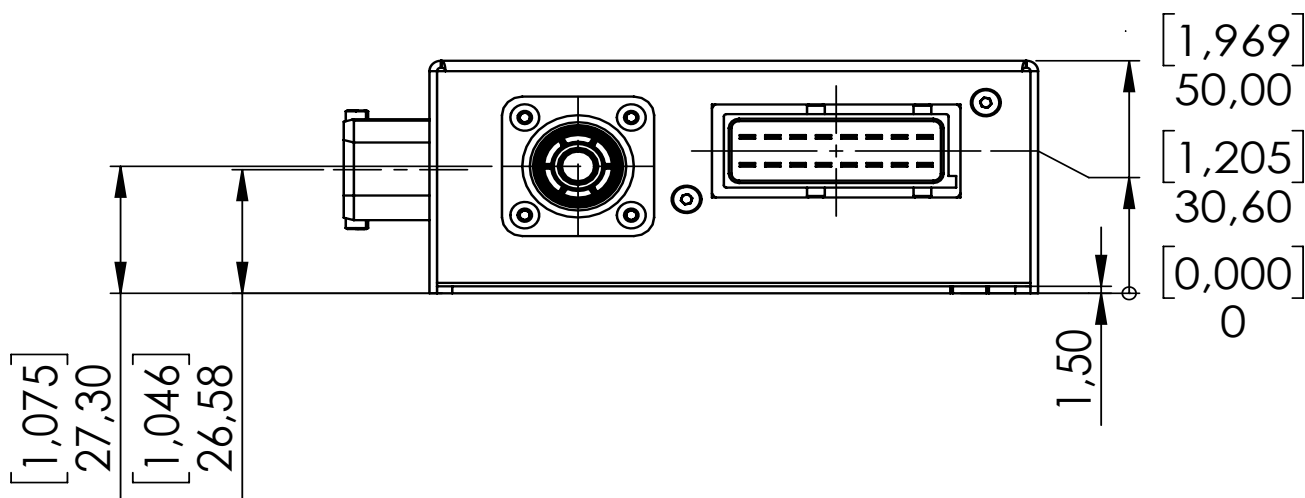
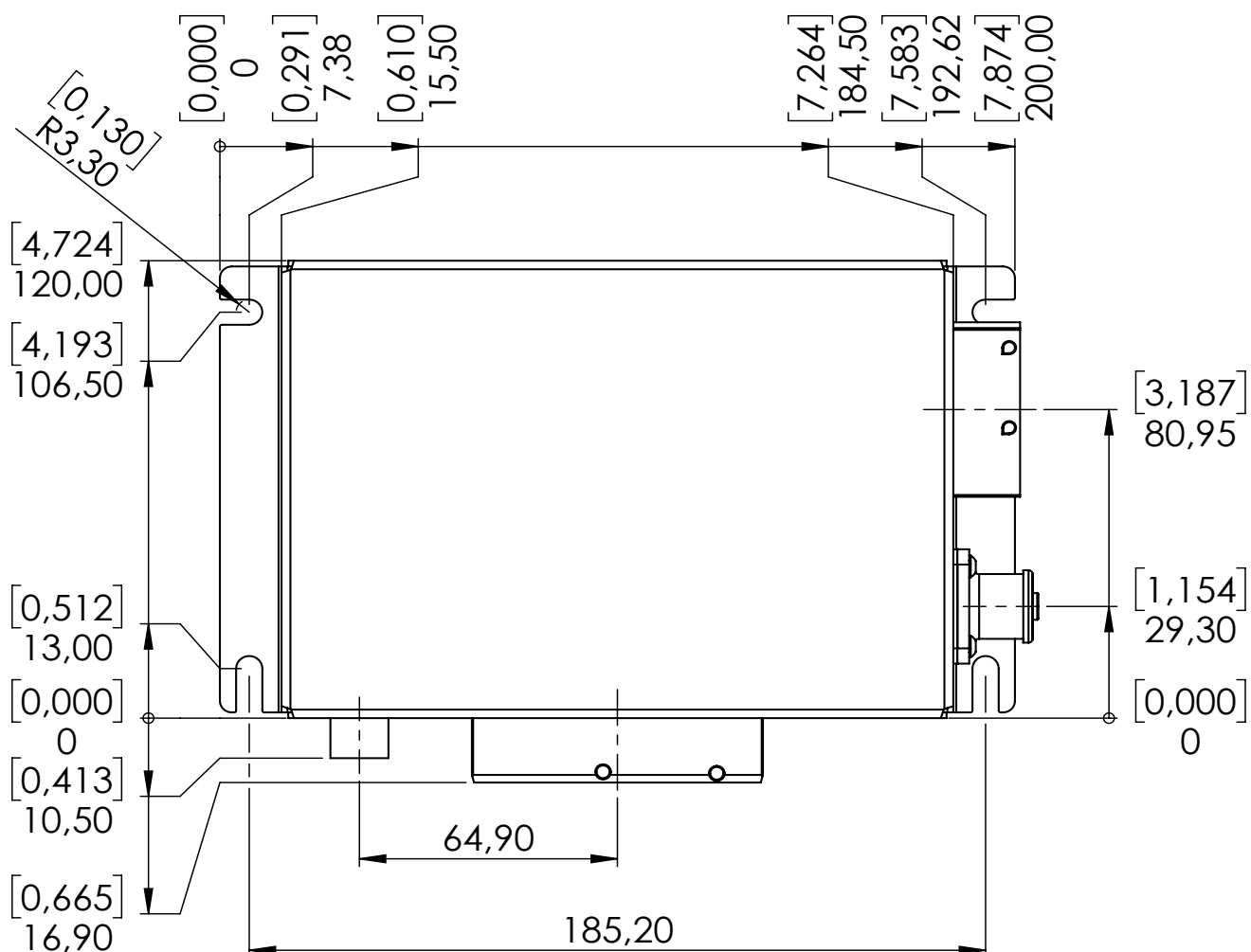

ASSEMBLY VARIANTS AND ORDERING INFORMATIONS CC27WP POWER-EXTENSION

	I/Os	Interfaces (Basis)	Wake Up	Remarks
	^A optionally as analog input 0...32 V, digital in- or digital output	CAN Bus High-Speed		
1.169.300.0110	Connector 4: 1...16 without PWM	CAN 0 CAN 1	CAN 0, CAN 1, LIN, KL15, DO_POWER	Connector: JPT 16-pol.
1.169.300.0070	Connector 4: 1...16 without PWM	CAN 0 CAN 1 CAN 2	CAN 0, CAN 1, CAN 2, LIN, KL15, DO_ POWER	Connector: JPT 16-pol.

ACCESSORIES

Description	Order number
Connector package Power Piggy	302391



Image similar

MANUFACTURER

MRS Electronic GmbH & Co. KG
Klaus-Gutsch-Str. 7
78628 Rottweil
Germany

NOTES ON WIRING AND CABLE ROUTING

The electronic system and the power outputs of a control unit must be supplied by the same power supply system.

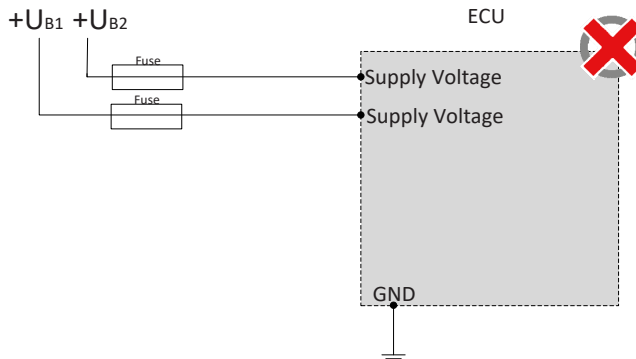
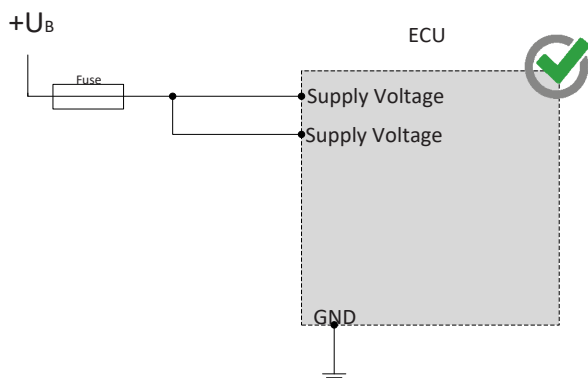

PWM outputs may not be connected with each other or bypassed.

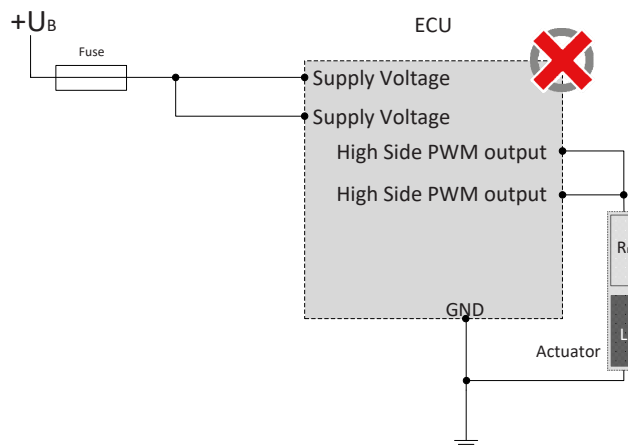
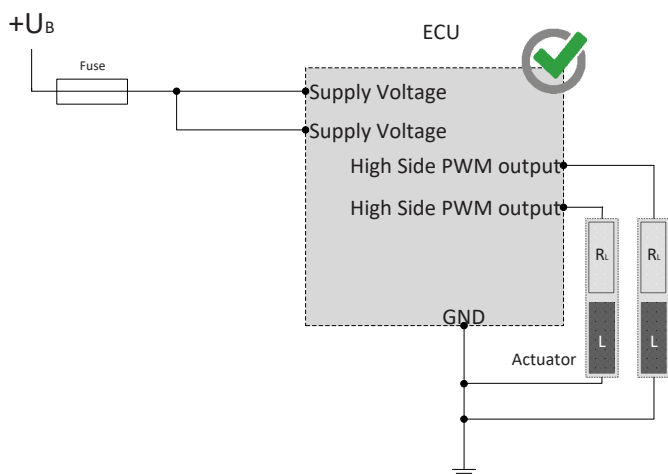

The pins (I/Os) can be used in combination and may not be switched externally against a higher voltage level than supply voltage.

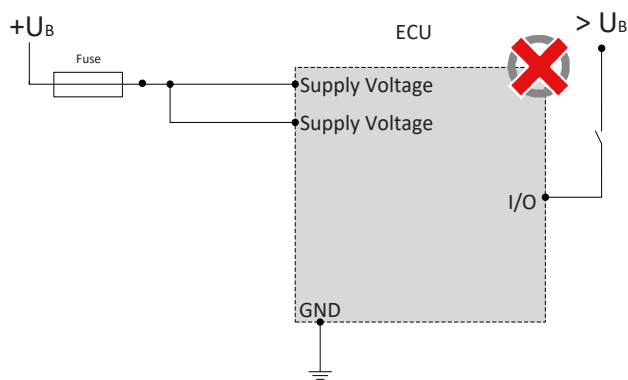
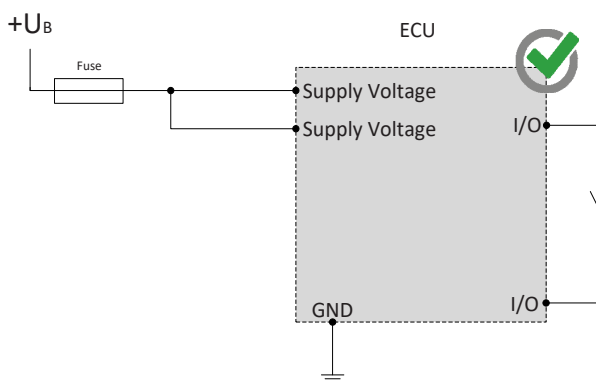

NOTES ON WIRING AND CABLE ROUTING

PWM- and higside outputs may only be switched to ground.

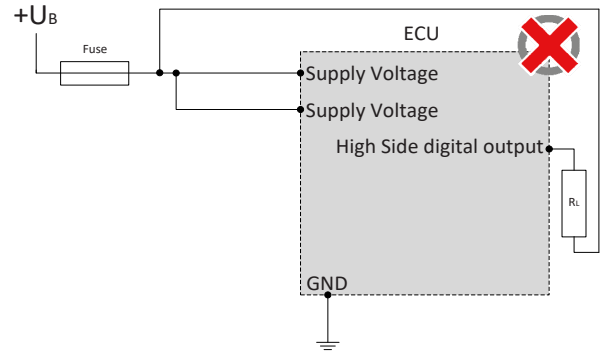
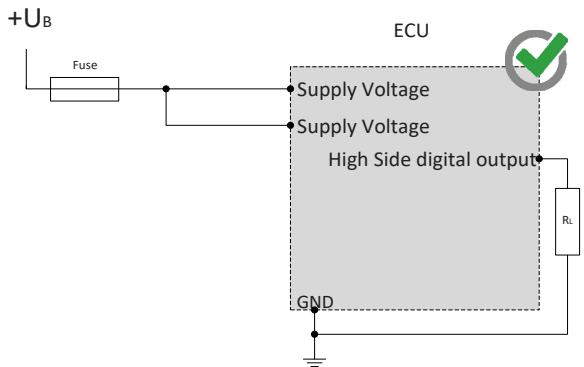
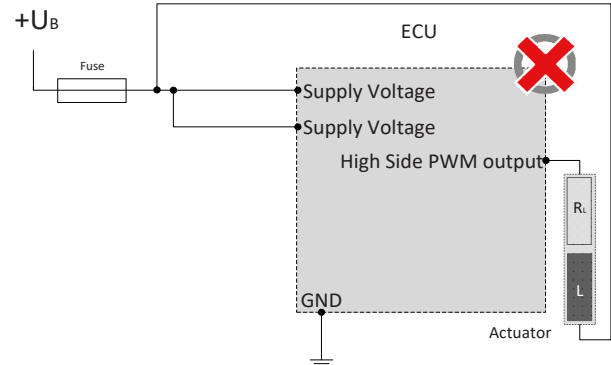
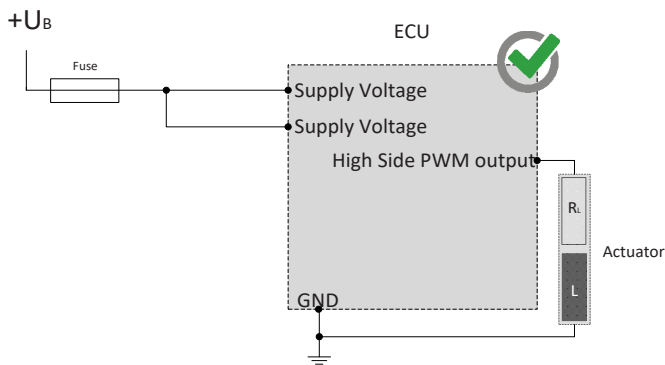

The sensor supplies can be "lifted" through an external circuitry, for example the creation of higher voltage, as they only work as a voltage source but not as voltage drain. The lift of a voltage source may lead to unforeseen malfunctions and damages of the control unit in case of permanent operation.

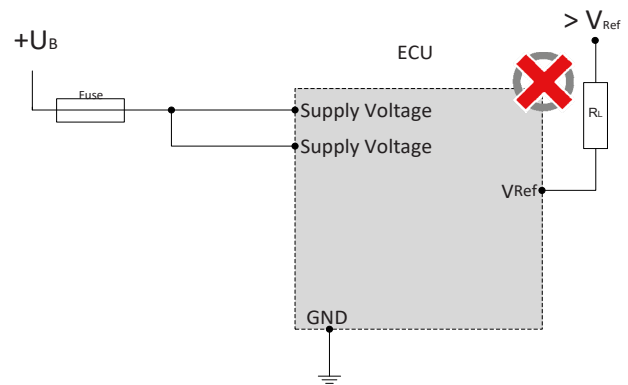
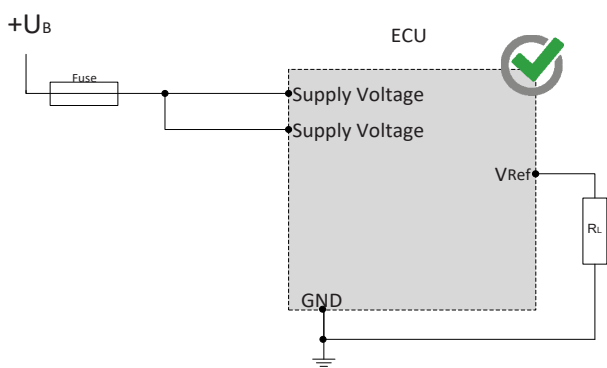

CAN bus communication is the main communication between the control unit and the vehicle. Therefore, connect the CAN bus with special care and check the correct communication with the vehicle to avoid undesired behavior.

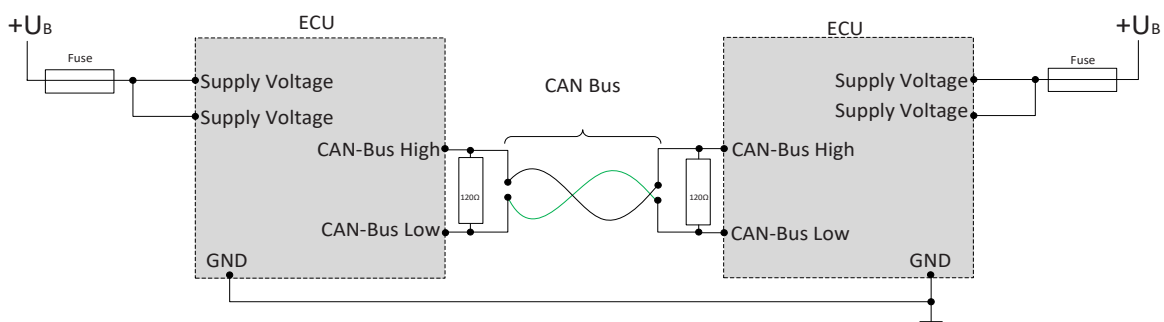

NOTES ON WIRING AND CABLE ROUTING

When using the input with pull-down resistance (using DOM_PD), you must not connect a greater voltage than 9 V to the input.

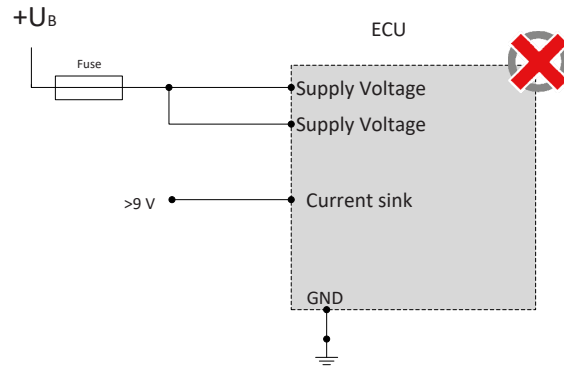
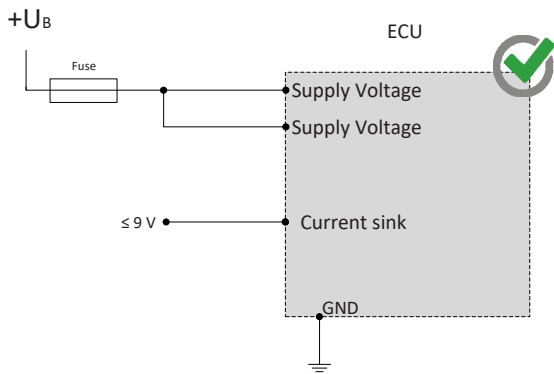

The control must be protected against overload (see performance data)

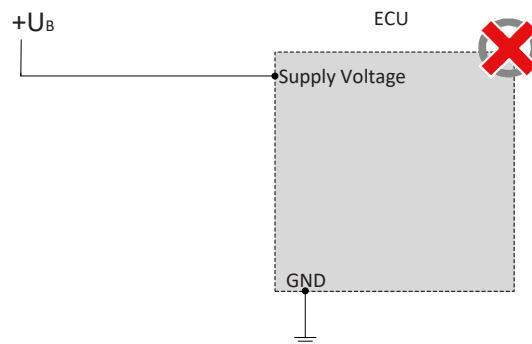
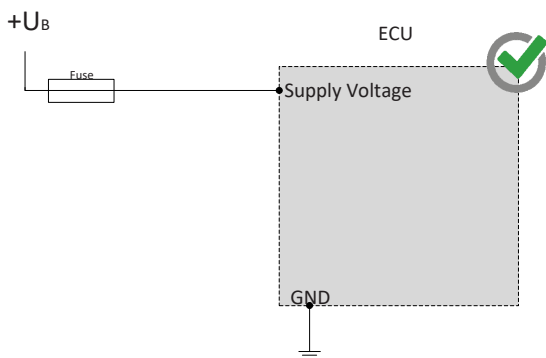

To prevent damage to the hardware, a ramp function, e.g. via the graphic programming block "Ramp", must be used. The description for this is stored in the Developers Studio.

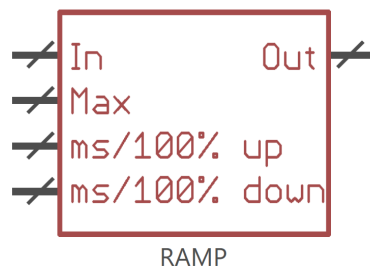

SAFETY AND INSTALLATION INFORMATION

It is essential to read the instructions in full thoroughly before working with the device.

Please note and comply with the instructions in the operating instructions and the information in the device data sheet, see www.mrs-electronic.com

Staff qualification: Only staff with the appropriate qualifications may work on this device or in its proximity.

SAFETY

-  **WARNING! Danger as a result of a malfunction of the entire system.**
Unforeseen reactions or malfunctions of the entire system may jeopardise the safety of people or the machine.
- Ensure that the device is equipped with the correct software and that the wiring and settings on the hardware are appropriate.

-  **WARNING! Danger as a result of unprotected moving components.**
Unforeseen dangers may occur from the entire system when putting the device into operation and maintaining it.
- Switch the entire system off before carrying out any work and prevent it from unintentionally switching back on.
 - Before putting the device into operation, ensure that the entire system and parts of the system are safe.
 - The device should never be connected or separated under load or voltage.

-  **CAUTION! Risk of burns from the housing.**
The temperature of the device housing may be elevated.
- Do not touch the housing and let all system components cool before working on the system.

PROPER USE

The device is used to control or switch one or more electrical systems or sub-systems in motor vehicles and machines and may only be used for this purpose. The device may only be used in an industrial setting.

-  **WARNING! Danger caused by incorrect use.**
The device is only intended for use in motor vehicles and machines.
- Use in safety-related system parts for personal protection is not permitted.
 - Do not use the device in areas where there is a risk of explosion.

Correct use:

- operating the device within the operating areas specified and approved in the associated data sheet.
- strict compliance with these instructions and no other actions which may jeopardise the safety of individuals or the functionality of the device.

Obligations of the manufacturer of entire systems

It is necessary to ensure that only functional devices are used. If devices fail or malfunction, they must be replaced immediately.

System developments, installation and the putting into operation of electrical systems may only be carried out by trained and experienced staff who are sufficiently familiar with the handling of the components used and the entire system.

It is necessary to ensure that the wiring and programming of the device does not lead to safety-related malfunctions of the entire system in the event of a failure or a malfunction. System behaviour of this type can lead to a danger to life or high levels of material damage.

The manufacturer of the entire system is responsible for the correct connection of the entire periphery (e.g. cable cross sections, correct selection/connection of sensors/actuators).

Opening the device, making changes to the device and carrying out repairs are all prohibited. Changes or repairs made to the cabling can lead to dangerous malfunctions. Repairs may only be carried out by MRS.

Installation

The installation location must be selected so the device is exposed to as low a mechanical and thermal load as possible. The device may not be exposed to any chemical loads.

Install the device in such a manner that the plugs point downwards. This means condensation can flow off the device. Single seals on the cables/leads must be used to ensure that no water gets into the device.

Putting into operation

The device may only be put into operation by qualified staff. This may only occur when the status of the entire system corresponds to the applicable guidelines and regulations.

FAULT CORRECTION AND MAINTENANCE

-  **NOTE The device is maintenance-free and may not be opened.**
- If the device has damage to the housing, latches, seals or flat plugs, it must be taken out of operation.

Fault correction and cleaning work may only be carried out with the power turned off. Remove the device to correct faults and to clean it.

Check the integrity of the housing and all flat plugs, connections and pins for mechanical damage, damage caused by overheating, insulation damage and corrosion. In the event of faulty switching, check the software, switches and settings.

Do not clean the device with high pressure cleaners or steam jets. Do not use aggressive solvents or abrasive substances.