



Operating Instructions

For the following types:

1.033 CAN I/O PLC / RS485 Gateway

(Rev.G)

1.033 CAN I/O PLC / RS232 Gateway

(Rev.G)

1.042 CAN Gateway Module

1.053 CAN I/O PLC Waterproof / RS485 Gateway

1.053 CAN I/O PLC Waterproof / RS232 Gateway

1.057 Universal Gateway 5x CAN

1.113 Micro SPS CAN LIN Gateway

1.114 Micro Gateway

1.156 Micro Gateway MGW

1.174 CAN RS232/RS485 Gateway

Contact data

MRS Electronic GmbH & Co. KG
Klaus-Gutsch-Str. 7
78628 Rottweil, Germany

Telephone: +49 741 28070
Internet: <https://www.mrs-electronic.com>
E-mail: info@mrs-electronic.com

Product

Product designation: Gateways

Types: 1.033 CAN I/O PLC / RS485 Gateway (Rev.G)
1.033 CAN I/O PLC / RS232 Gateway (Rev.G)
1.042 CAN Gateway Module
1.053 CAN I/O PLC Waterproof / RS485 Gateway
1.053 CAN I/O PLC Waterproof / RS232 Gateway
1.057 Universal Gateway 5x CAN
1.113 Micro PLC CAN LIN Gateway
1.114 Micro Gateway
1.156 Micro Gateway MGW (with S32K processor)
1.174 CAN RS232/RS485 Gateway

Serial number: see type plate



Document

Name: Gateways_GA1_1.6
Version: 1.6
Date: 08/2022

The original operating instructions were composed in German.
MRS Electronic GmbH & Co. KG compiled this document with the utmost diligence and based on the current state of technology. MRS Electronic GmbH & Co. KG will not assume any liability or responsibility for errors in content or form, missing updates as well as any possibly resulting damages or drawbacks. Our products are developed according to European norms and standards. Therefore, the use of these products is currently limited to the area of the European Economic Area (EEA). If products are to be used in another area, market access research must be carried out beforehand. You can do this yourself as the market introducer or you are welcome to contact us and we will discuss how to proceed together.

Table of Contents

1	User information.....	1
1.1	About these operating instructions	1
1.2	Copyright.....	3
1.3	Warranty conditions	3
2	Safety.....	4
2.1	Hazards.....	4
2.2	Staff qualifications	5
2.3	Obligations of the manufacturers of complete systems.....	6
3	Product description	8
4	Transport / Storage	9
4.1	Transport.....	9
4.2	Storage.....	9
5	Intended use	10
6	Assembly	11
6.1	Mounting location.....	11
6.2	Mounting position.....	11
6.3	Fastening.....	11
7	Electric installation	12
7.1	Wiring.....	13
8	Commissioning	15
9	Software	16
10	Fault removal and maintenance	17
10.1	Cleaning	18
10.2	Fault removal.....	18
11	Disassembly and disposal.....	19
11.1	Disposal.....	19

1 User information

1.1 About these operating instructions

The manufacturer MRS Electronic GmbH & Co. KG (hereinafter referred to as MRS) delivered this product to you in its entirety and functionally sound. The operating instructions provide information about how to:

- Install the product
- Service the product (cleaning)
- Uninstall the product
- Dispose of the product

It is essential to read these operating instructions thoroughly and completely before working with the product. We strive to compile all the information for safe and complete operation. However, should you have any questions not answered by these instructions, please contact MRS.

Storage and transfer of the operating instructions

These instructions as well as all other product-related documentation relevant for different applications must always be kept on hand and be available in the vicinity of the product.

Target group of the operating instructions

These instructions address trained experts who are familiar with handling electronic assemblies. Trained experts are those persons who can assess the tasks assigned to her/him and recognize possible dangers due to her/his expert training, knowledge and experience as well as her/his knowledge of the relevant standards and regulations.

Validity of the operating instructions

The validity of these instructions goes into effect with the transfer of the product from MRS to the operator. The version number and approval date of the instructions are included in the footer. Changes to these operating instructions are possible any time and without the specification of any reasons.

INFORMATION



The current version of the operating instructions replaces all previous versions.

Warning information in the operating instructions

The operating instructions contain warning information before a call to action which includes the risk of property damage or personal injury. The measures for averting risks described in the instructions must be implemented. Warning information is structured as follows:

DANGER!



SOURCE AND CONSEQUENCE

Plus explanation, where needed.

▶ Prevention.

- Warning symbol: (Warning triangle) indicates the danger.
- Signal word: Specifies the seriousness of the danger
- Source: Designates the type or source of the danger.
- Consequence: Specifies the consequences in case of noncompliance
- Prevention: Informs how to avert the danger.

DANGER!



Designates an immediate, serious threat which will with certainty lead to serious injury or even death if the danger is not averted.

WARNING!



Designates a possible threat which may lead to serious injury or even death if the danger is not averted.

CAUTION!



Designates a potentially dangerous situation which may lead to mild or medium property damage or physical injury if the danger is not averted.

INFORMATION



Sections with this symbol provide important information about the product or how to handle the product.

Symbols used in the operating instructions



General warning sign.



Beware of electrical current.



Beware of hot surface.

1.2 Copyright

These operating instructions contain information protected by copyright. The contents or excerpts of the contents may not be copied or reproduced in any other way without prior consent from the manufacturer.

1.3 Warranty conditions

See the General Terms and Conditions MRS Electronic GmbH & Co. KG at <https://www.mrs-electronic.de/agb/>

2 Safety

This chapter includes all the information you should know in order to safely install and operate the product.

2.1 Hazards

The gateway has been constructed with the newest technology and recognized safety-relevant regulations. Danger for persons and/or property may arise in case of improper use. Lack of compliance with the rules for work safety may result in damages. This section describes all the possible hazards which may be relevant during the assembly, installation and commissioning of the gateway.

Faulty operations

Faulty software, circuits or parameter setting may cause unforeseen reactions or malfunctions through the complete system.

⚠ WARNING!**DANGER DUE TO MALFUNCTION OF THE COMPLETE SYSTEM**

Unforeseen reactions or malfunctions of the complete system may endanger the safety of people and machine.

- ▶ Please make sure that the gateway is equipped with the proper software and that the circuits and parameter settings are compliant with the hardware.
-

Moving components

The complete system may create unforeseen dangers when commissioning and servicing the gateway.

⚠ WARNING!**SUDDEN MOVEMENTS OF COMPLETE SYSTEM OR OF COMPONENTS**

Danger due to unprotected moving components.

- ▶ Before performing any work, shut down the complete system and secure it against unintended restart.
 - ▶ Before commissioning the system, please make sure that the complete system and all parts of the system are in a safe state.
-

Elevated temperature

CAUTION!



DANGER OF BURNS!

The casing of the gateway may exhibit an elevated temperature.

- ▶ Please do not touch the casing and let all system components cool down before working on the system.

2.2 Staff qualifications

These operating instructions repeatedly refer to the qualifications of the employees who can be trusted to perform various tasks for installation and maintenance. The three groups are:

- Specialists/Experts
- Skilled persons
- Authorized persons

This product is not suitable for use by persons (incl. Children) who are mentally or physically disabled or do not have enough experience or sufficient knowledge of the product unless supervised or having attended a detailed training regarding the use of the gateway by a person who is responsible for the safety of this person.

Specialists/Experts

Specialists and experts are, for example, fitters or electrician who are capable of assuming different tasks, such as transport, assembly and installation of the product with the instructions of an authorized person. The people in question must be experienced in handling the product.

Skilled persons

Skilled persons are those persons who have sufficient knowledge of the subject in question due to their specialist training and are familiar with the relevant national occupational protection provisions, accident prevention regulations, guidelines and generally recognized rules of technology. Skilled persons must be capable of securely assessing the results of their work and familiarize themselves with the contents of these operating instructions.

Authorized persons

Authorized persons are those persons who are permitted to perform the work due to legal regulations or who have been approved to perform certain tasks by MRS.

2.3 Obligations of the manufacturers of complete systems

- Tasks for system development, installation and commissioning of electric systems may only be performed by trained and experienced staff, see Chapter 2.2 Staff qualifications.
- The manufacturer of the complete system must ensure that no defective or faulty gateways are used. In case of failure or malfunctions, the gateway must be replaced immediately.
- The manufacturer of the complete system must ensure that the circuitry and programming of the gateway do not lead to a safety-relevant malfunction of the complete system in case of a failure or malfunction.
- The manufacturer of the complete system is responsible for the correct connection of all the peripherals (such as cable profiles, plugs, crimps, correct selection/connection of sensors/actuators).
- The gateway may not be opened.
- No changes and/or repairs may be performed on the gateway.
- If the gateway falls down, it may no longer be used and must be returned to MRS to be checked.
- The manufacturer of the complete system must inform the end customer about all potential dangers.

The manufacturer must also take the following aspects into consideration when using the gateway:

- Gateways with wiring suggestions provided by MRS do not constitute a systematic responsibility for complete systems.
- Safe operation cannot be guaranteed for gateways used as prototypes or samples in the complete system.
- Faulty circuitry and programming of the gateway may lead to unforeseen signals to the outputs of the gateway.
- Faulty programming or parameter setting of the gateway may lead to dangers during operation of the complete system.
- It must be ensured when the gateway is released that the supply of the electric system, of the final stages and of the external sensor supply are shut down jointly.
- Gateways without factory-made software programmed more than 500 times may not be used in complete systems any longer.

The risk of accidents is reduced if the manufacturer of the complete systems observes the following points:

- Adherence to the statutory regulations regarding accident prevention, occupational safety and environmental protection.
- Provision of all documents required for installation and maintenance.
- Monitoring of the cleanliness of the gateway and of the complete system.
- The responsibilities for the assembly of the gateway must be clearly specified by the manufacturer of the complete system. The assembly and maintenance staff must be regularly instructed.
- And work and maintenance performed on electric energy sources is always associated with possible dangers. Persons not familiar with these kinds of devices and systems may cause harm to themselves and others.
- The installation and maintenance staff of a system with electric devices must be instructed by the manufacturer regarding potential dangers, required safety measures and applicable safety provisions before beginning work.

3

Product description

The gateways by MRS Electronic are the central point of contact for all control units. You can transmit and evaluate all information and data, so all ECUs can communicate and work with each other. They are used primarily in the automotive sector, where they control and coordinate all control units in the vehicle. This enables error-free and secure communication between all controllers.

For gateways with DZ60 Processor (see datasheet): The software tool CANgraph and the suitable flash programming tool MRS Developers Studio or programming with a C-programming system are used for graphic programming.

For gateways with S32K Processor (see datasheet) you can program the gateways with our Applies Studio. Now with the own developed graphic program surroundings and the improved program possibilities it is even easier to be programmed your application. You find the documentation online under: applies.dev

4 Transport / Storage

4.1 Transport

The product must be packed in suitable transport packaging and secured against sliding around. During transport, the statutory provisions regarding securing loads must be observed.

If the gateway falls down, it may no longer be used and must be returned to MRS to be checked.

4.2 Storage

Store the product in a dry place (no dew), dark (no direct sunlight) in a clean room which can be locked. Please observe the permissible environmental conditions in the data sheet.

5 Intended use

The gateway is used to coordinate and communicate between controllers in vehicles and work machines and may only be used for this purpose. The gateway may only be operated in industrial applications.

You are within regulations:

- If the gateway is operated within the operating ranges specified and approved in the corresponding data sheet.
- If you strictly adhere to the information and sequence of tasks described in these operating instructions and do not engage in unauthorized actions which may risk your safety and the functionality of the gateway.
- If you comply with all specified safety instructions

WARNING!



DANGER DUE TO UNINTENDED USE!

The gateway is only intended to be used in vehicles and work machines.

- ▶ An application in safety-relevant system parts for personal protection is not permitted.
 - ▶ Please do not use the gateway in explosive areas.
-

Misuse

- Use of the product in conditions and requirements differing from those specified by the manufacturer in technical documentation, data sheets and operating instructions.
- Non-compliance with the safety information and information regarding assembly, commissioning, maintenance and disposal specified in the operating instructions.
- Conversions and changes of the gateway.
- Use of the gateway or parts thereof which are damaged or corroded. The same goes for seals and cables.
- Operation in a condition with access to live parts.
- Operation without the safety measures intended and provided by the manufacturer.

MRS only guarantees/is liable for the gateway corresponding to the published specifications. If the product is used in a way not described in these operation instructions or in the data sheet of the gateway in question, the protection of the gateway will be impaired, and the warranty claim is void.

6 Assembly

Assembly work may only be performed by qualified staff (see Chapter 2.2). The gateway may only be operated after having installed in a fixed location.

INFORMATION



If the gateway falls down, it may no longer be used and must be returned to MRS to be checked.

6.1 Mounting location

The mounting location must be selected as such that the gateway is subjected to as low a mechanical and thermal load as possible. The gateway may not be exposed to chemicals.

INFORMATION



Please observe the permissible environmental conditions in the data sheet.

6.2 Mounting position

Mount the gateway in such a way that the connectors point downwards. This ensures that possible condensation water can flow off. Individual seals of the cables/wires ensure that no water can enter the gateway.

6.3 Fastening

Gateway with fastening straps

The gateway must be screwed to the complete system at both side fastening straps. The selection of the connecting elements, securing the connections and the torque are determined by the manufacturer of the complete system. Please observe the specified hole distance in the data sheet.

7 Electric installation

Electric installation work may only be performed by qualified staff (see Chapter 2.2). The electric installation of the unit may only be performed in idle condition. The gateway may never be connected or disconnected on-load or when live.

WARNING!



SUDDEN MOVEMENTS OF COMPLETE SYSTEM OR OF COMPONENTS

Danger due to unprotected moving components.

- ▶ Before performing any work, shut down the complete system and secure it against unintended restart.
- ▶ Please make sure that the complete system and all parts of the system are in a safe state.
- ▶ Please ensure that the gateway is connected correctly. Check the pin assignment.

Gateway with plug connectors

1. Please ensure that the correct cable harness is connected to the gateway. Follow the connection diagram and documents of the complete system.
2. Please ensure that the mating plug of the cable harness (not included) is compatible.
3. Please ensure that the gateway is free of dirt and moisture.
4. Please ensure that the mate plug of the cable harness (not included) does not exhibit any damages due to overheating, insulation damages and corrosion.
5. Please ensure that the mating plug of the cable harness (not included) is free of dirt and moisture.
6. Connect the plug connector until the locking catch latches or the locking mechanism (optional) can be actuated.
7. Lock the plug or ensure that the grommet (optional) of the mating plug is fully attached.
8. Close the open pins with blind plugs to prevent liquids from entering.
 - ▶ The commissioning process can now be performed, see Chapter 8.

7.1 Wiring

INFORMATION



Always use an external fuse in the power supply line to protect the device against overvoltage. For further information about the correct fuse rating, please refer to the corresponding data sheet.

- The wiring must be connected with the utmost diligence.
- All cables and the way they are laid must comply with applicable regulations.
- The connected cables must be suitable for temperatures min. 10°C above the max. permitted environmental temperature.
- The cables must comply with the requirements and wire cross-sections specified in the technical data.
- When laying cables, the possibility of mechanical damages of the wire insulation on sharp edges or moving metal parts must be excluded.
- Cables must be laid so they are strain-relieved and friction-free.
- The cable routing must be selected in such a way that the cable harness only moves identically to the direction of movement of the controller/plug. (Attachment controller/cable/strain relief on the same underground). A strain relief is necessary.

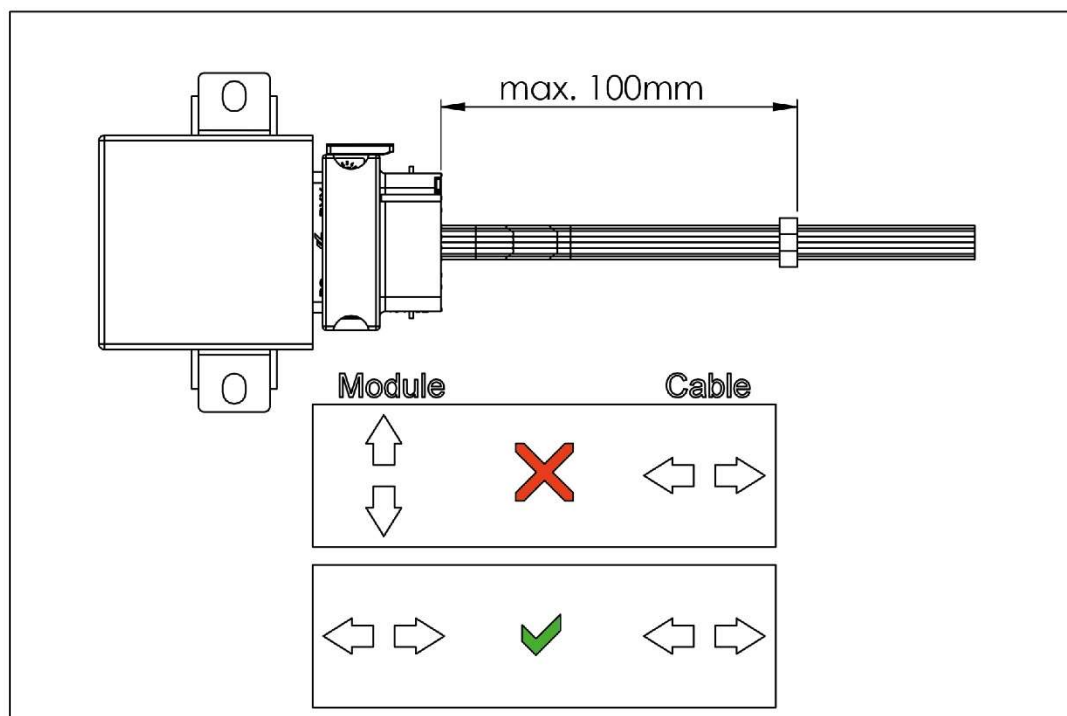

Illustration similar

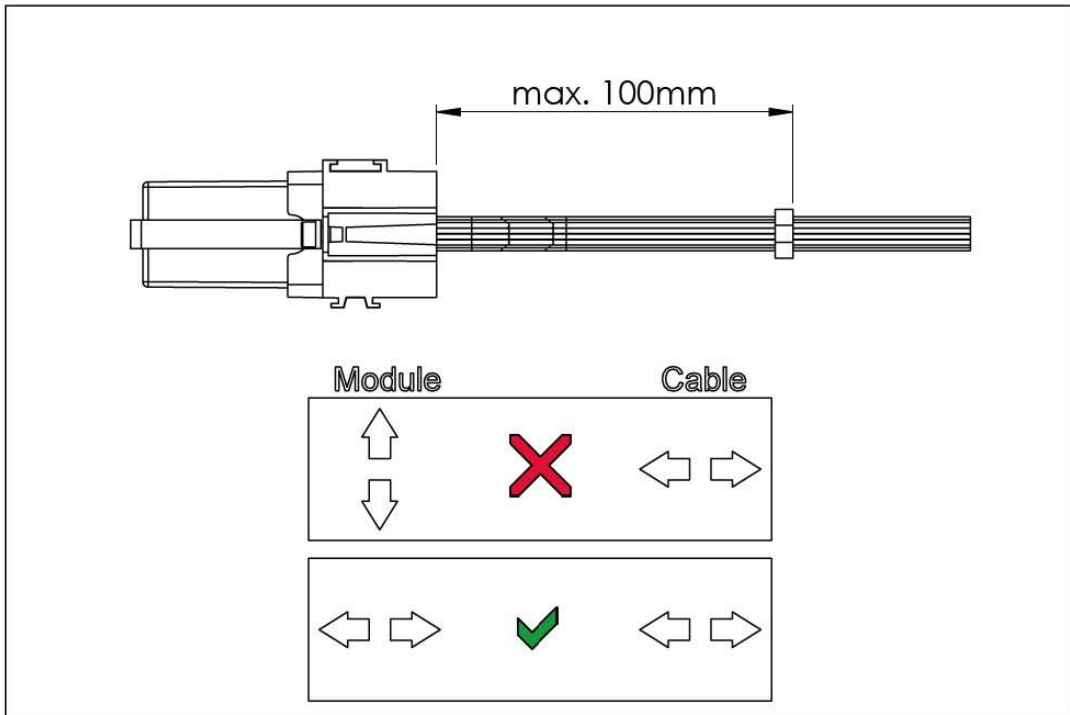

Illustration similar

8 Commissioning

Commissioning work may only be performed by qualified staff (see Chapter 2.2). The unit may only be commissioned if the condition of the complete system complies with the applicable guidelines and regulations.

INFORMATION



MRS recommends a functional test on site.

⚠ WARNING!



SUDDEN MOVEMENTS OF COMPLETE SYSTEM OR OF COMPONENTS

Danger due to unprotected moving components.

- ▶ Before commissioning the system, please make sure that the complete system and all parts of the system are in a safe state.
- ▶ If necessary, secure all hazard areas with barrier tapes.

The operator must ensure that

- the correct software has been embedded and corresponds with the circuitry and parameter setting of the hardware (only for gateways supplied by MRS without software).
- no persons are present in the vicinity of the complete system.
- the complete system is in a safe state.
- Commissioning is performed in a safe environment (horizontal and solid ground, no weather impact)

9 Software

The installation and/or replacement of device firmware / software must be performed by MRS Electronic GmbH & Co. KG or by an authorized partner in order for the warranty to remain valid.

INFORMATION



Gateways supplied without software can be programmed using MRS Developers Studio.
▶ More information available in the MRS Developers Studio manual.

10 Fault removal and maintenance

INFORMATION



The gateway is maintenance-free and may not be opened.

- ▶ If the gateway exhibits any damages on the casing, locking catch, seals or flat plugs, it must be shut down.

Fault removal and cleaning work may only be performed by qualified staff (see Chapter 2.2). Fault removal and cleaning work may only be performed in idle condition. Remove the gateway for fault removal and cleaning. The gateway may never be connected or disconnected on-load or when live. After fault removal and cleaning work has been completed, please follow the instructions in Chapter 7 Electric installation.

⚠ WARNING!



SUDDEN MOVEMENTS OF COMPLETE SYSTEM OR OF COMPONENTS

Danger due to unprotected moving components.

- ▶ Before performing any work, shut down the complete system and secure it against unintended restart.
- ▶ Before beginning fault removal and maintenance work, please make sure that the complete system and all parts of the system are in a safe state.
- ▶ Remove the gateway for fault removal and cleaning.

⚠ CAUTION!



DANGER OF BURNS!

The casing of the gateway may exhibit an elevated temperature.

- ▶ Please do not touch the casing and let all system components cool down before working on the system.

⚠ CAUTION!



DAMAGE OR SYSTEM FAILURE DUE TO IMPROPER CLEANING!

The gateway may be damaged due to improper cleaning processes and cause unintended reactions throughout the complete system.

- ▶ The gateway should not be cleaned with a high-pressure cleaner or a water jet.
- ▶ Remove the gateway for fault removal and cleaning.

10.1 Cleaning

INFORMATION



Damages due to improper cleaning agents!

The gateway may be damaged when cleaning it with high-pressure cleaners, steam jets, aggressive solvents or scouring agents.

- ▶ Do not clean the gateway with high-pressure cleaners or steam jets. Do not use any aggressive solvents or scouring agents.

Only clean the gateway in a clean environment free of dust.

1. Please follow all safety instructions and deenergize the complete system.
2. Do not use any aggressive solvents or scouring agents.
3. Let the gateway dry.
 - ▶ Install the clean gateway pursuant to the instructions in Chapter 7.

10.2 Fault removal

1. Please ensure that fault removal measures are performed in a safe environment (horizontal and solid ground, no weather impact)
2. Please follow all safety instructions and deenergize the complete system.
3. Check that the system is intact.
 - ▶ Remove damaged gateways and dispose of in accordance with national environmental regulations.
4. Remove the mate plug and/or remove the gateway from the slot.
5. Check all flat plugs, connectors and pins for mechanical damages due to overheating, insulation damage and corrosion.
 - ▶ Damaged gateways and gateways with corroded contacts must be removed and disposed of in accordance with national environmental regulations.
 - ▶ Dry gateway and contacts in case of moisture.
 - ▶ If needed, clean all contacts.

Faulty operations

In case of faulty operations, check the software, circuitry and parameter settings.

11 Disassembly and disposal

Disassembly and disposal may only be performed by qualified staff (see Chapter 2.2). Disassembly of the unit may only be performed in idle condition.

WARNING!



SUDDEN MOVEMENTS OF COMPLETE SYSTEM OR OF COMPONENTS

Danger due to unprotected moving components.

- ▶ Before performing any work, shut down the complete system and secure it against unintended restart.
- ▶ Before disassembling the system, please make sure that the complete system and all parts of the system are in a safe state.

CAUTION!



DANGER OF BURNS!

The casing of the gateway may exhibit an elevated temperature.

- ▶ Please do not touch the casing and let all system components cool down before working on the system.

Gateway with plug connectors

1. Unlock the lock and/or the locking catch of the mate plug.
2. Gently remove the mate plug.
3. Loosen all screw connections and remove the gateway.

11.1 Disposal

Once the product is disused, it must be disposed of in accordance with the national environmental regulations for vehicles and work machines.